

# INSTALLATION MANUAL

## *AIR COOLED MINI CHILLER*

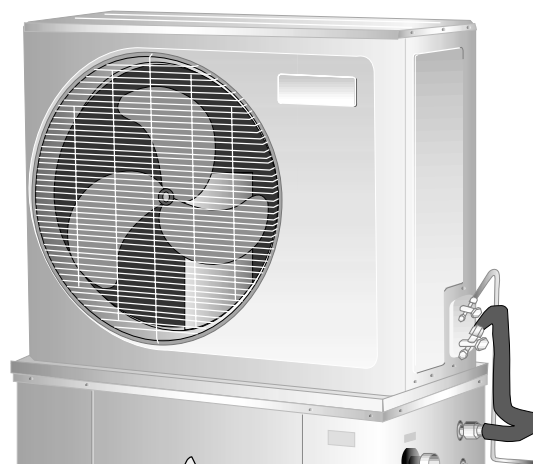

Большая библиотека технической документации

<https://splitsystema48.ru/instrukcii-po-ekspluatácii-kondicionerov.html>

каталоги, инструкции, сервисные мануалы, схемы.

# INSTALLATION MANUAL

This manual provides the procedures of installation to ensure a safe and good standard of operation for the air conditioner unit.

Special adjustment may be necessary to suit local requirements.

Before using your air conditioner, please read this instruction manual carefully and keep it for future reference.

## AIR COOLED MINI CHILLER

### MODEL

#### Reference Model

AC040A

AC050A

AC058A

AC040AR

AC050AR

AC058AR

AC075B

AC100B

AC125B

AC075BR

AC100BR

AC125BR

#### Models

AMAC040A / MAC040A

AMAC050A / MAC050A

AMAC058A / MAC058A

AMAC040AR / MAC040AR

AMAC050AR / MAC050AR

AMAC058AR / MAC058AR

AMAC075B / MAC075B

AMAC100B / MAC100B

AMAC125B / MAC125B

AMAC075BR / MAC075BR

AMAC100BR / MAC100BR

AMAC125BR / MAC125BR



Большая библиотека технической документации

<https://splitsystema48.ru/instrukcii-po-ekspluatacii-kondicionerov.html>

каталоги, инструкции, сервисные мануалы, схемы.

## CONTENTS

- Safety Precautions	page 2	- Water Filling	page 6
- Outline And Dimensions	page 3	- Electrical Wiring Connection	page 6
- Unit Installation	page 4	- Chiller Control Operation Guide	page 8
- Refrigerant Circuit	page 6	- Trouble Shooting	page 9

## SAFETY PRECAUTIONS

Before installing the air conditioner unit, please read the following safety precautions carefully.

### **Warning**

- Installation and maintenance should be performed by qualified persons who are familiar with local code and regulation, and experienced with this type of appliance.
- All field wiring must be installed in accordance with the national wiring regulation.
- Ensure that the rated voltage of the unit corresponds to that of the name plate before commencing wiring work according to the wiring diagram.
- The unit must be GROUNDED to prevent possible hazards due to insulation failure.
- All electrical wiring must not touch the refrigerant piping, compressor or any moving parts of the fan motors.
- Confirm that the unit has been switched OFF before installing or servicing the unit.

### **IMPORTANT**

**DO NOT INSTALL OR USE THE AIR CONDITIONER UNIT IN A LAUNDRY ROOM.**

### **Caution**

**Please take note of the following important points when installing.**

- **Do not install the unit where leakage of flammable gas may occur.**



If gas leaks and accumulates around the unit, it may cause fire ignition.

- **Ensure that the drainage piping is connected properly.**



If the drainage piping is not connected properly, it may cause water leakage which will dampen the furniture.

- **Do not overcharge the unit.**



This unit is factory pre-charged. Overcharge will cause over-current or damage to the compressor.

- **Ensure that the units panel is closed after service or installation.**



Unsecured panels will cause unit to operate noisily.

## OUTLINE AND DIMENSIONS

### AC075/100/125

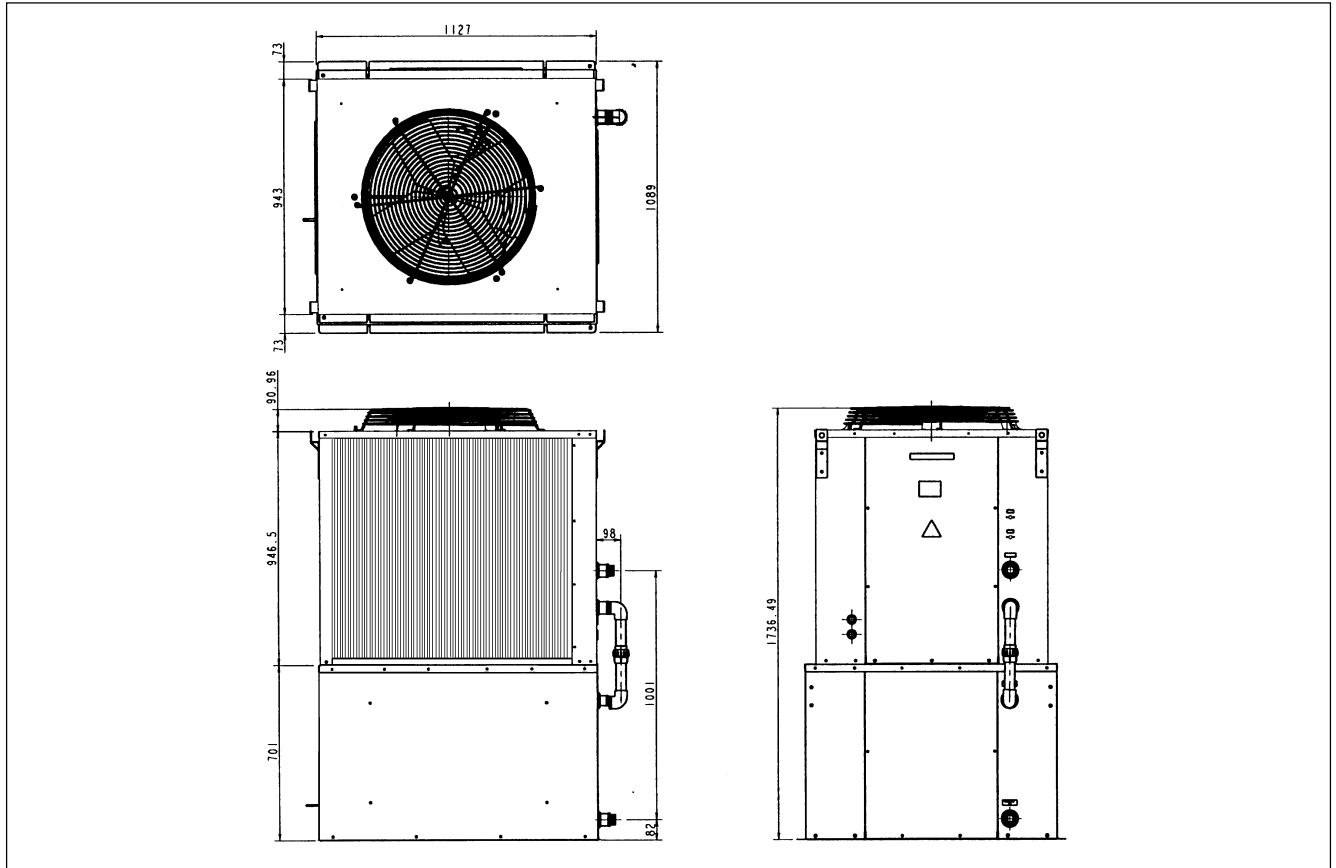

### AC040/050/058

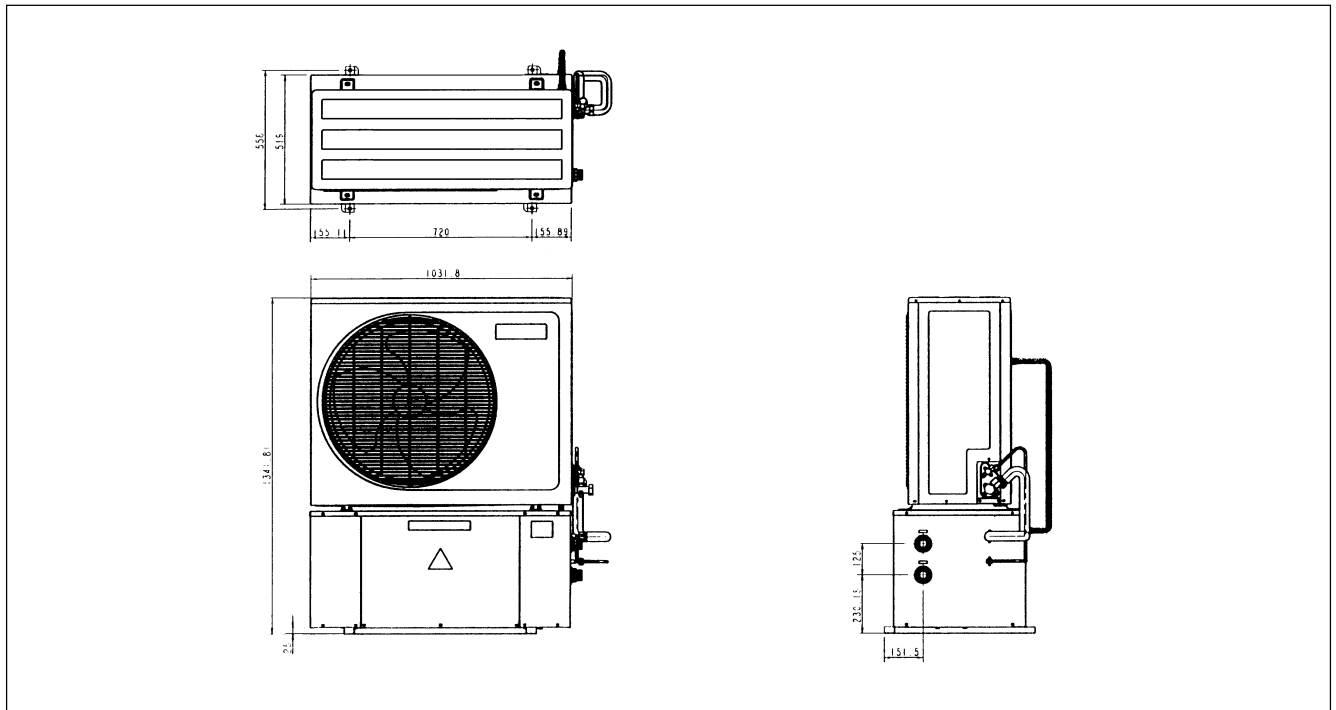

## UNIT INSTALLATION

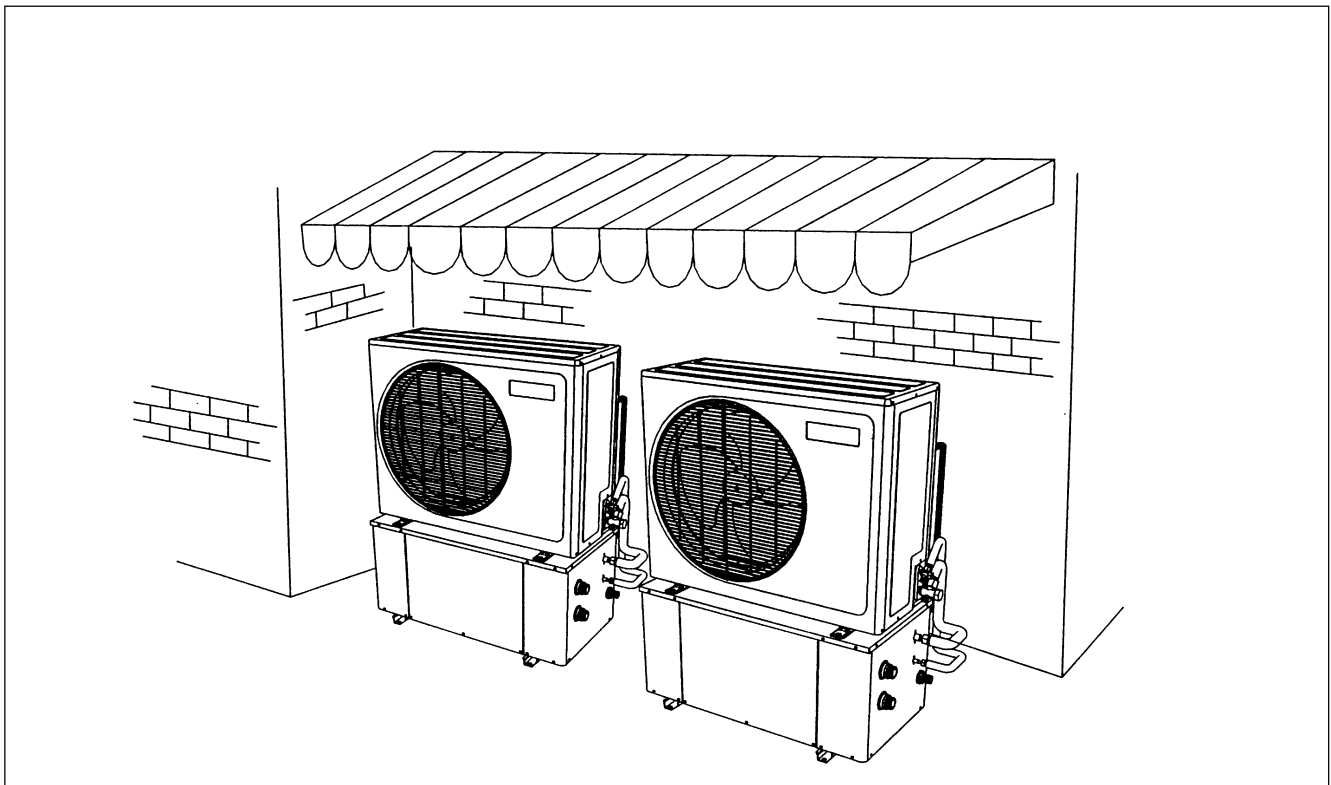
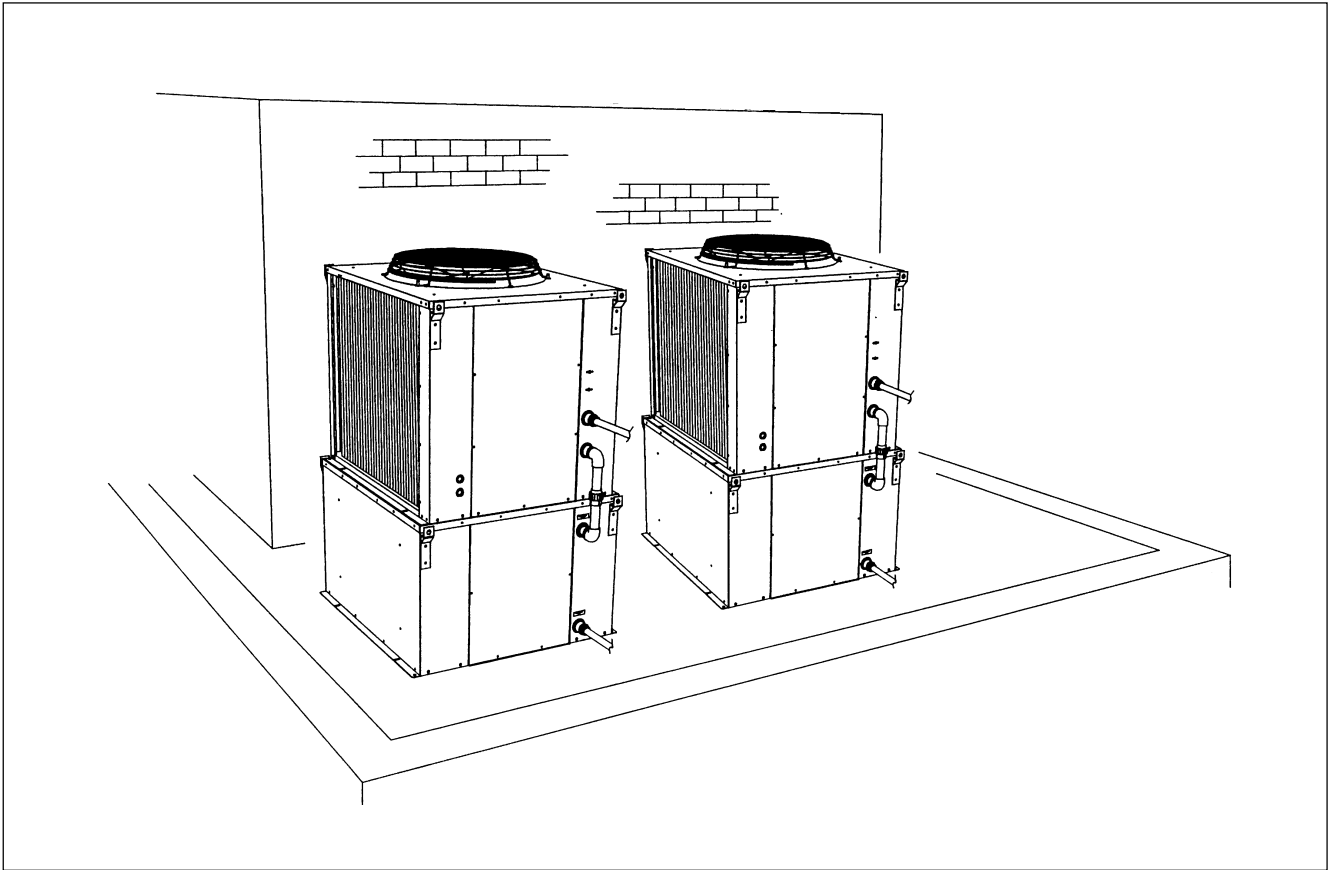

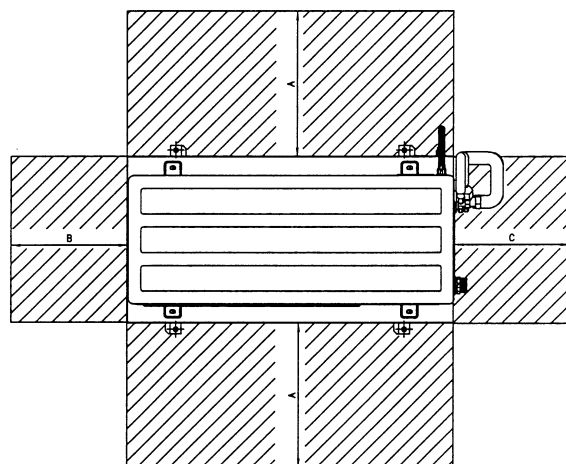

MODEL	A	B	C
AC040 – 058A AC040AR – 058AR	950mm	900mm	900mm

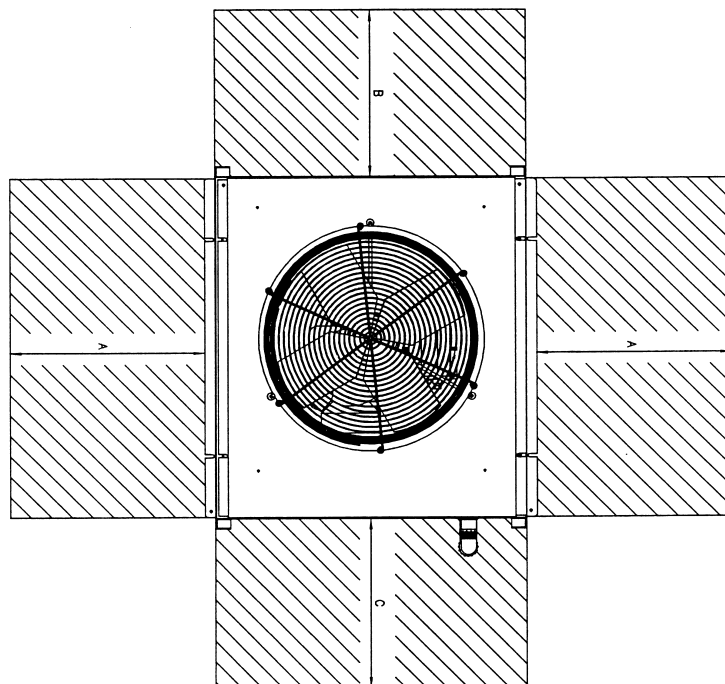

MODEL	A	B	C
AC075 – 125B	950mm	900mm	900mm

## REFRIGERANT CIRCUIT

All mini chiller series is precharged with refrigerant R22, the only pipe work that needs to be done is to connect the water piping between the mini chiller (outdoor unit) and the fan coil (indoor unit).  
Purging of the refrigerant R22 in AC040A/AR ~ 058A/AR series is only required if the unit is installed separately with hydraulic kit.

## WATER FILLING

In this close water system, the pump can cater for longer piping compared to normal direct expansion units.  
After connecting all the pipes and equipments, filling water in the circuit, perform leak check for all the connections and joints. Do not start the unit when the system is leaking.  
To optimize the capacity of the system, ensure that the system is free of air bubbles or air-traps. Air traps in the system seriously unbalance the whole system. It is very important to check the whole water system especially ensuring that the water tank is not full of water. This protection step is not only to prevent tank & piping corrosion but also to ensure optimum performance of the unit. This can be done by releasing the air trap from the auto-air-vent (water tank) and manual air vent (installed in the highest place of the water system).

## ELECTRICAL WIRING CONNECTION

MODEL	AC040A/AR ~ AC058A/AR	AC075B/BR	AC100B/BR	AC125BR
Voltage Range	380 – 420V/3ph / 50Hz +⊕			
Power Supply Cable Size Number of conductor	4	6	10	16
Interconnection Cable Size (mm <sup>2</sup> )	2.5	2.5	2.5	2.5

**IMPORTANT :** These values are for information only. They should be checked and selected to comply with local and/or national codes of regulations. Which is also subject to the type of installation and size of conductors used.

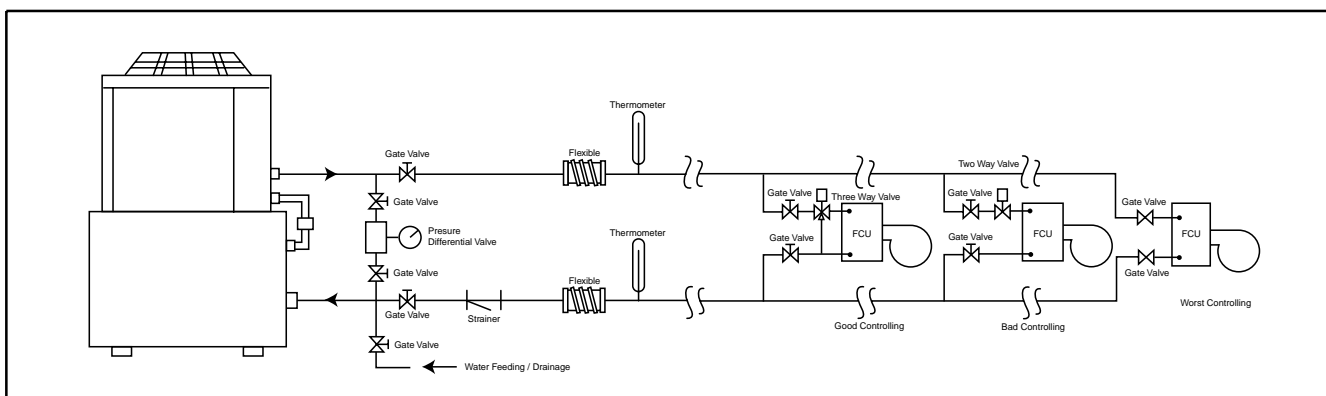
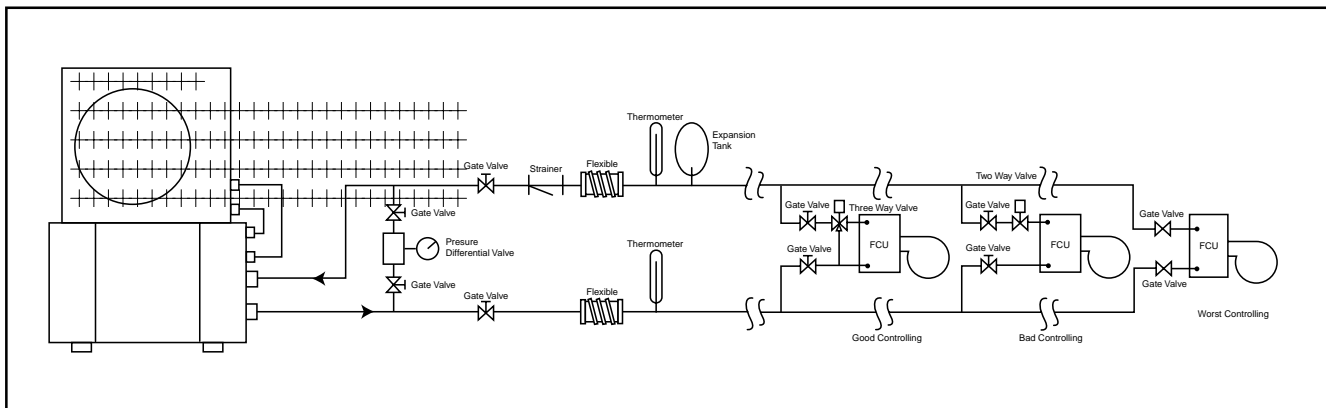

AC 040AR ~ 058AR

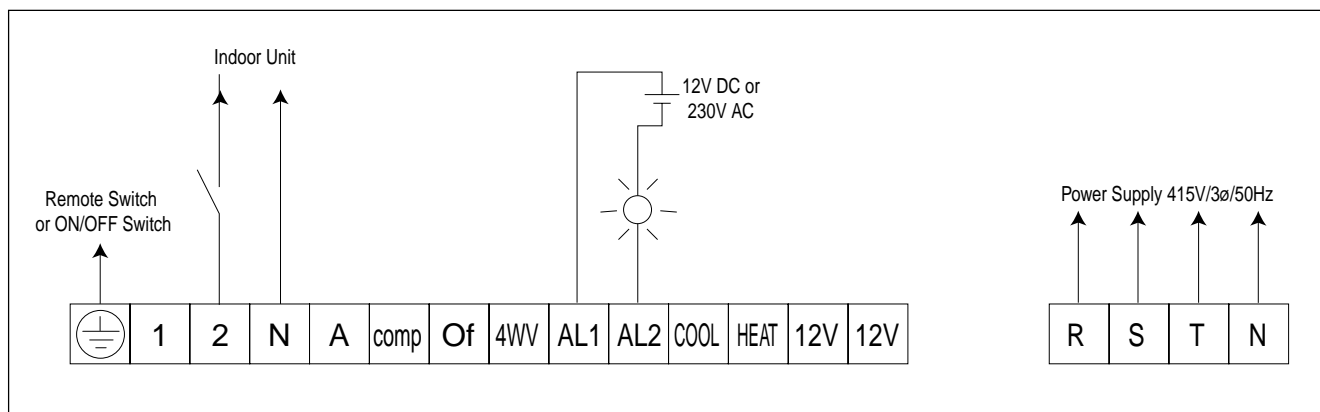

AC 040A ~ 058A

AC 040A ~ 058A

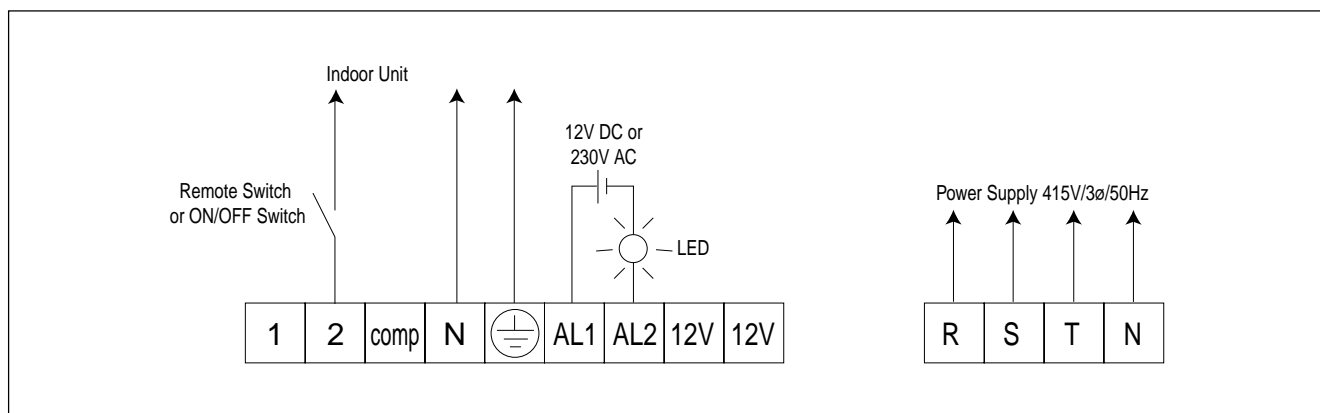

AC 075B ~ 125B

AC 075B ~ 125B (EXPORT SPEC)

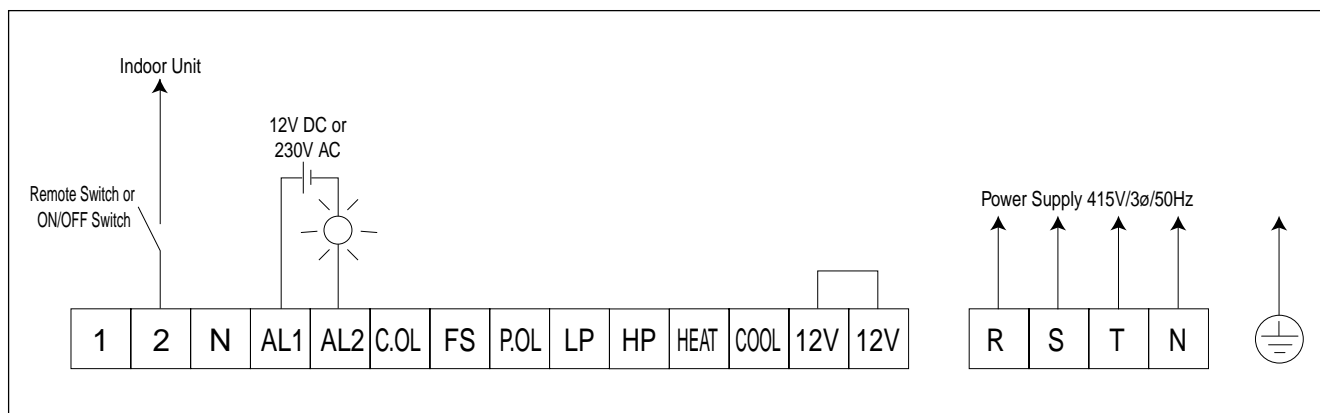

AC 075BR ~ 125BR

AC 075BR ~ 125BR (EXPORT SPEC)

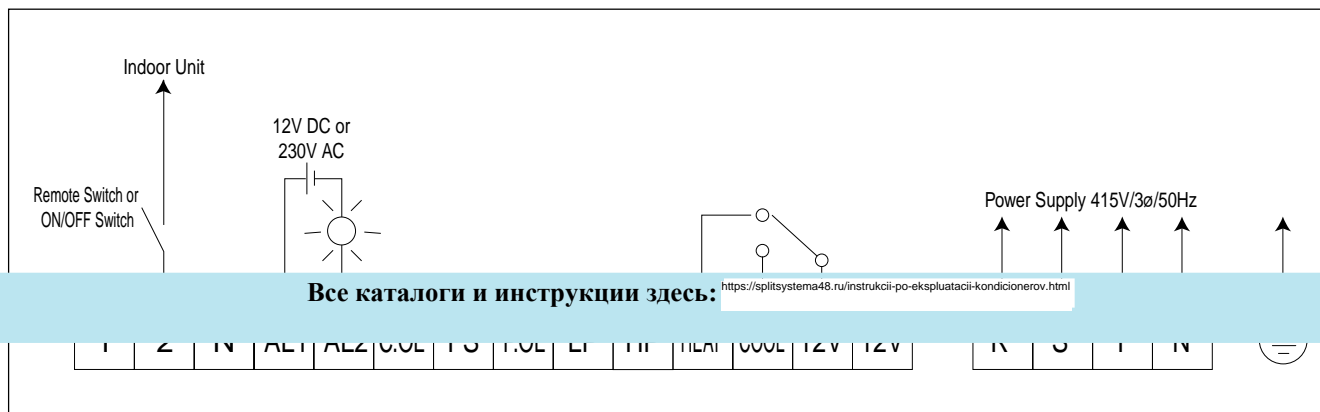



## CHILLER CONTROL OPERATION GUIDE

1. ON/OFF Toggle switch
  - Push up to start the chiller.
  - Push down to switch off the chiller for servicing and maintenance.
2. Water Entering Temperature °C (Factory Setting)
  - Cooling Mode, setting : 12°C
  - Heating Mode, setting : 40°C
3. Antifreeze Protection for Cooling Mode
  - Setting : 2°C
4. Temperature Setting
  - For cooling mode, press the SW1 button switch once. The green LED will blink for a few seconds. Adjust the small variable resistor (VR3) to the required water entering temperature of between (10°C - 15°C) by using a suitable tool.
  - For extremely low water temperature (obtained by adding glycol), set the water entering temperature to between 3°C to 9°C by adjusting the DIP switch (SW2).

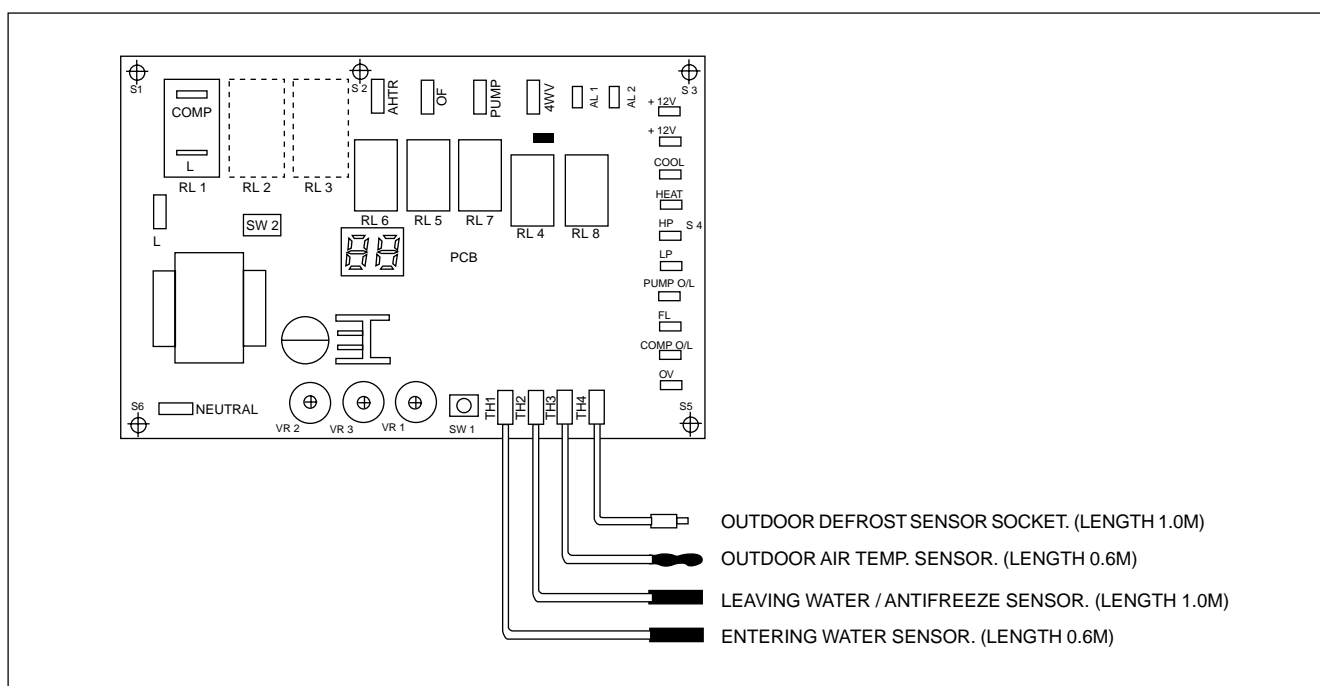

If the DIP switch is set to (0,0,0), the setting temperature will be determined by the VR3 setting. Otherwise,

- For heating mode, press the SW1 button switch twice and then the red LED will blink for a few seconds. Adjust the variable resistor (VR1) by setting it to the required water entering temperature which (35°C ~ 50°C) for heating mode.
- To prevent water from freezing in the system, adjust the variable resistor VR2. The setting range is between +3°C to -4°C.

Set Temperature °C	SW2		
	SW 2-3	SW2-2	SW2-1
Set by VR3	0	0	0
3	0	0	1
4	0	1	0
5	0	1	1
6	1	0	0
7	1	0	1
8	1	1	0
9	1	1	1

## TROUBLE SHOOTING

If any malfunction occurs, immediately switch off the power supply to the unit, and contact a local dealer if necessary. Some simple trouble shooting tips are given below.

SYMPTOMS	POSSIBLE CAUSES	REMEDIAL ACTION
1. Compressor does not start.	<ul style="list-style-type: none"> <li>* No power supply.</li> <li>* Fuses blown or automatic circuit break-down open.</li>   <li>* Thermal relay tripped.</li> <li>* Defective contactor or coil.</li> <li>* Unit is stopped because safety device has tripped.</li> <li>* Loose wires.</li>   <li>* Compressor faulty.</li> </ul>	<ul style="list-style-type: none"> <li>* Check power supply.</li> <li>* Look for short circuit or grounded wires in motor windings. Replace fuses and reset circuit breakers when the fault has been corrected. Check tightness and soundness of all electrical connections.</li> <li>* Reset the thermal relay and carefully monitor units operation when it is restarted.</li> <li>* Repair or replace.</li> <li>* Determine the type of safety shut down and correct the default before the unit is restarted.</li> <li>* Check wire connections and tighten terminal screws.</li> <li>* Contact local dealer.</li> </ul>
2. Fan does not work.	<ul style="list-style-type: none"> <li>* No power supply.</li> <li>* Fan motor faulty.</li> </ul>	<ul style="list-style-type: none"> <li>* Check power supply.</li> <li>* Contact local dealer.</li> </ul>
3. Air cooled mini chiller does work, but cools unsufficiently.	<ul style="list-style-type: none"> <li>* Thermostat setting too high.</li> <li>* Condenser coil dirty.</li> <li>* Obstacle blocking air inlet or outlet of the unit.</li> <li>* Insufficient refrigerant in the system.</li> <li>* Improper water flow rate.</li> <li>* Water source contains contamination.</li> </ul>	<ul style="list-style-type: none"> <li>* Reset thermostat.</li> <li>* Contact local dealer.</li> <li>* Remove the obstacle.</li>   <li>* Contact local dealer.</li> <li>* Contact local dealer.</li> <li>* Contact local dealer.</li> </ul>
4. PCB display 'CO'.	<ul style="list-style-type: none"> <li>* Compressor thermal relay tripped.</li> <li>* Terminal loose.</li> </ul>	<ul style="list-style-type: none"> <li>* Reset the thermal relay and carefully monitor units operation when it is restarted.</li> <li>* Tighten terminal screws.</li> </ul>
5. PCB display 'PO'.	<ul style="list-style-type: none"> <li>* Pump thermal relay tripped.</li> <li>* Terminal loose.</li> </ul>	<ul style="list-style-type: none"> <li>* Reset the thermal relay and carefully monitor units operation when it is restarted.</li> <li>* Tighten terminal screws.</li> </ul>
6. PCB display 'FL'.	<ul style="list-style-type: none"> <li>* Flow switch connection loose.</li> <li>* Wrong terminal in flow switch.</li> <li>* Water volume not enough.</li> <li>* Flow switch blade too short or too long.</li> </ul>	<ul style="list-style-type: none"> <li>* Tighten terminal screws.</li> <li>* Change the terminal.</li> <li>* Add water into the system.</li> <li>* Replace flow switch.</li> </ul>
7. PCB, display 'HP'.	<ul style="list-style-type: none"> <li>* Discharged pressure too high</li> <li>* Overcharge.</li> <li>* Coil dirty.</li> <li>* Condenser Fan does not work</li> <li>* Expansion valve stuck in open position</li> </ul>	<ul style="list-style-type: none"> <li>* Reset the pressure switch and observe the units operation when it is restarted.</li> <li>* Contact local dealer.</li> <li>* Clean the coil with chemical detergent.</li> <li>* Contact local dealer.</li> <li>* Replace it.</li> </ul>
8. PCB display 'LP'.	<ul style="list-style-type: none"> <li>* Suction pressure too low</li> <li>* Undercharge</li> <li>* Gas Leak</li> <li>* Water flow rate too low</li> </ul>	<ul style="list-style-type: none"> <li>* Reset the pressure switch and observe the units operation when it is restarted.</li> <li>* Contact local dealer.</li> <li>* Contact local dealer.</li> <li>* Adjust the flow rate.</li> </ul>
9. PCB display 'E3'.	<ul style="list-style-type: none"> <li>* Antifreeze protection activated.</li> <li>* Water flow rate too low</li> <li>* Bubble in the heat exchanger</li> </ul>	<ul style="list-style-type: none"> <li>* Check the temperature setting.</li> <li>* Adjust the flow rate.</li> <li>* Increase the water volume.</li> </ul>

Все каталоги и инструкции здесь: <https://splitssystema48.ru/instrukcii-po-ekspluatacii-kondicionerov.html>

---

**OYL MANUFACTURING COMPANY SDN. BHD.**

JALAN PENGAPIT 15/19, P.O. BOX 7072, 40702 SHAH ALAM, SELANGOR DARUL EHSAN, MALAYSIA.



2



20/07/2000, 14:49

**Большая библиотека технической документации**  
<https://splitsystema48.ru/instrukcii-po-ekspluatacii-kondicionerov.html>  
**каталоги, инструкции, сервисные мануалы, схемы.**